

MELLOTT COMPANY

TECHNICAL DATA

MC6163W



WATER SYSTEM

- Unit is Pre-Plumbed For Single Point Fresh Water Connection (8" Pipe-8-Bolt Flange)
- Two (2) 1 1/2" Chase Water Connections w/ Gate Valve For Even Distribution Between Screws
- Manifold w/ Flow Control Valves For Individual Spray Bars
- Eleven (11) Screen Spray Bars, Each w/ V-Jet Nozzles

SCREEN CHUTES & FINES CHUTE

- Slurry Style Screen Feed Chute To Pre-Soak Material
- Chutes Constructed From 3/16" Mild Steel w/ 3/16" AR400 Liners
- Oversize Discharge Chute w/ Two (2) Sets Of Finger Gates For Blending
- Reversible Discharge Chutes
- Fines Flume w/ Wash Back Line

CHASSIS

- Heavy Duty Fabricated Frame w/ Cribbing Supports
- Dual Axle Suspension w/ Eight (8) 11R24.5 Tires
- Road Ready (Air Brakes, Light Kit, Mud Flaps)

ACCESS

- Walkway Access Around Three (3) Sides of Screen w/ Ladder Access to Grade

SCREEN

- Metso FS253, 6'x16', 3 Deck, Horizontal
- Triple-Shaft, MV2 Mechanism
- Weld-Free Side Plates w/ Huck Bolt Construction
- Single-Crown-Construction Decks For Side Tensioned Media
- 50 HP, 1200 RPM, TEFC (NEMA C) Motor
- Replaceable Feed Box & Discharge Lip Liners

FINE MATERIAL WASHER

- Masaba Twin 36"x25' Fine Material Washer
- 1/4" Mild Steel Tub Construction
- Welded Steel Flights w/ Replaceable 1" Urethane Shoes
- Adjustable Discharge Chute
- Two (2) 15 HP, 1800 RPM, TEFC Motors

AVAILABLE OPTIONS

- Pre-Wired Electrical Starter Panel
- Hydraulic Leveling Legs w/ Power Pack



OUR FOUNDATION. SAFETY, INTEGRITY, COMMITMENT, RESPECT & EXCELLENCE.

MELLOTT COMPANY

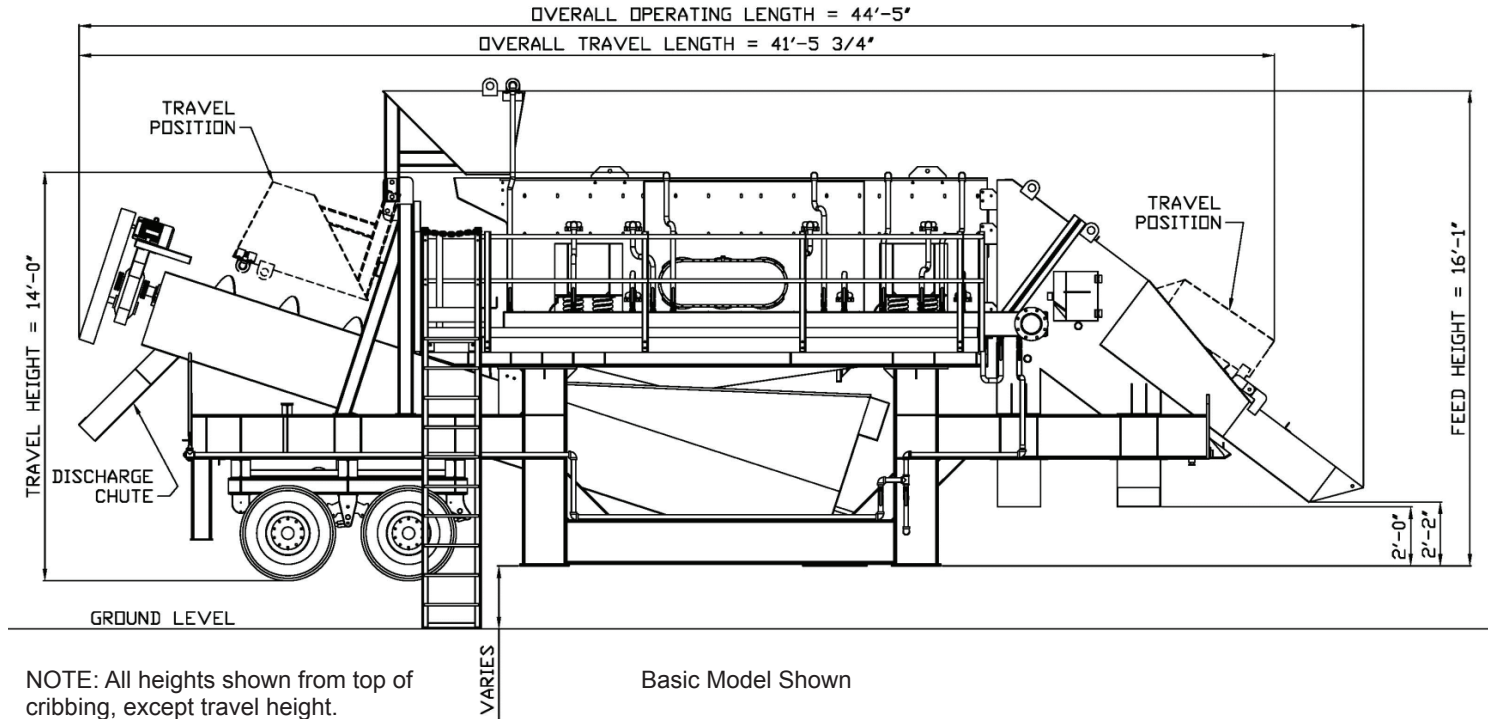

METSO FS253 6'x16' SCREEN

- Nominal Max Feed Size 4"
- Max Capacity 400 STPH

MASABA TWIN 36"x25' FINE MATERIAL WASHER

- Max Feed Size 3/8"
- Capacity 210 STPH @ 100% Screw Speed

PHYSICAL/OPERATING CHARACTERISTICS

- Overall Length 44'-5"
- Feed Height 16'-1"
- Travel Width 12'-0"
- Travel Height 14'-0"

Total Unit Weight 68,000 Lbs

Specifications are subject to change without notice.

Model MC6163W 090513-1

100 MELLOTT DRIVE, WARFORDSBURG, PA 17267 ■ WWW.MELLOTTCOMPANY.COM

AGGREGATE, SLAG, CONSTRUCTION AND POWER INDUSTRIES

FOR MORE INFORMATION CONTACT

800-634-5634

SALES@MELLOTT.COM