

NOTE: Basic model shown.

- **VIBRATING GRIZZLY FEEDER**
 - Metso HR 52" x 20' Vibrating Feeder
 - 40 HP, 1800 RPM, TEFC Electric Motor
 - 14' Pan w/ Replaceable ¾" AR Liners
 - 6' Grizzly Section w/ Adjustable Bars @ 4" Openings
- **JAW CRUSHER**
 - Metso C120 Jaw w/ Integral Motor Mount
 - Feed Opening 47" Wide x 34" Deep
 - 200 HP Crusher Duty Motor 1200 RPM, TEFC
 - Closed Side Setting 2 ¾" – 8"
 - Composite Guards, Crusher Feed Chute
- **CHASSIS**
 - Heavy Duty Fabricated Frame Complete w/ Cribbing Supports
 - Triple Axle Suspension with Twelve 11R24.5 Tires
 - Road Ready (Airbrakes, Light Kit, Mud Flaps)
- **UNDER CRUSHER CONVEYOR**
 - 20 HP, 48" BW x 35' Long Conveyor
 - Channel Frame Construction
 - CEMA C5 Idlers
 - Rubber Impact Bed @ Load Zone
- **AVAILABLE OPTIONS**
 - Hydraulic Breaker and Support Structure
 - Pre-Wired Electrical Starter Panel
 - Additional Hopper Capacity up to 39 Cubic Yards
 - Hydraulic Leveling Legs w/ Power Pack
 - Quad-Axle Suspension

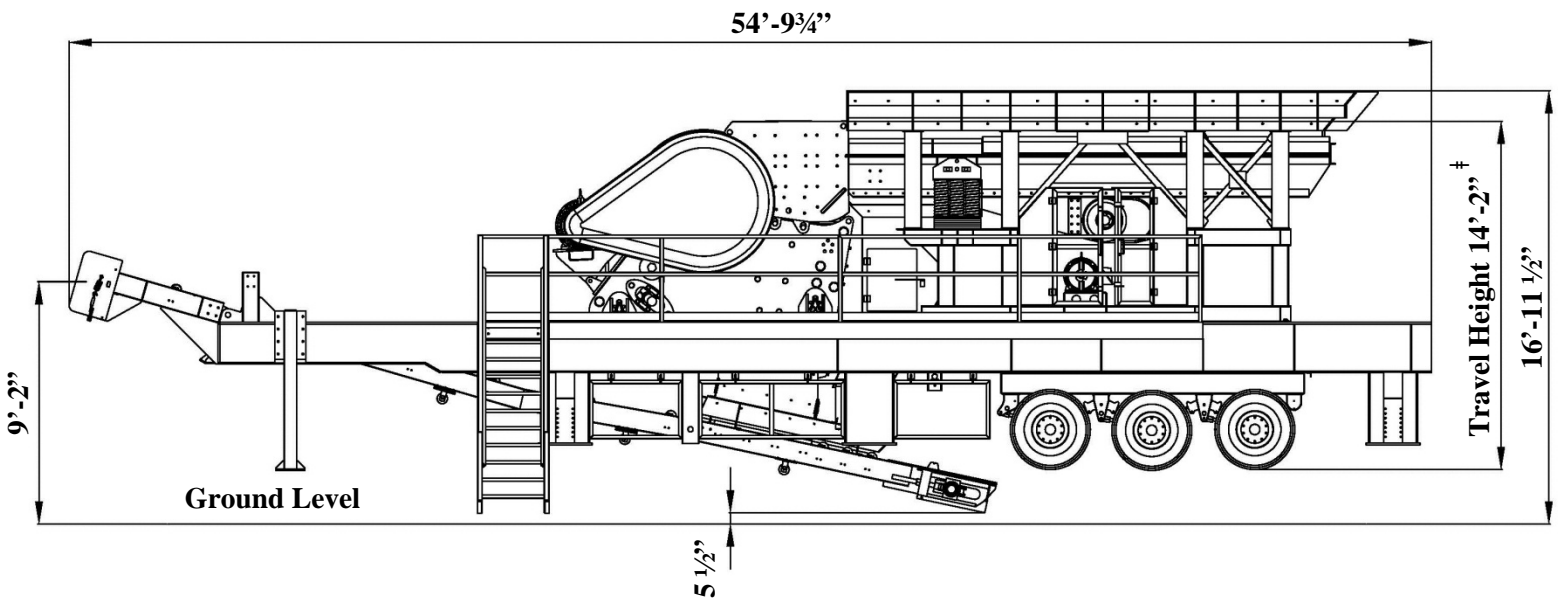



Basic Model Shown.

‡ - Travel height does not include feeder stand. Feeder stand to ship separate.

• **CRUSHER**

- Max Feed Size.....27" Maximum Plant Capacity.....600 STPH

• **PHYSICAL/OPERATING CHARACTERISTICS**

- Overall Length.....55'-9"
- Overall Height.....16'-11½"
- Travel Height.....14'-2"
- Ground Clearance.....0'-5½"
- Travel Width.....11'-10"
- Feed Height.....16'-11½"
- Discharge Height.....9'-2"
- Trailer 1 Weight.....102,200 Lbs

Total Unit Weight.....139,451 Lbs

Specifications are subject to change without notice.

Model MC120P 041613-REV 1

100 MELLOTT DRIVE, WARFORDSBURG, PA 17267 www.mellottcompany.com

Aggregate, Slag, Construction and Power Industries

For more information contact

800-634-5634

sales@mellotts.com