

NO. 110 9429 0195

ALL INFORMATION CONTAINED ON THIS DRAWING IS CONSIDERED TO BE BOTH CONFIDENTIAL AND PROPRIETARY BY Rexnord Inc. NO USE OR REPRODUCTION THEREOF MAY BE MADE WITHOUT THE EXPRESS WRITTEN CONSENT OF Rexnord Inc.

NOTE:

1 A TRAMP RELEASE CYL. REPAIR KIT IS AVAILABLE CONTAINING THESE PARTS. ORDER PART CODE NO. 9429 0197, SIZE A4

BILL OF MATERIAL

ITEM NO.	PART NUMBER	QTY REQ	PART NAME	DWG SIZE	WT EACH IN
10	9429 0195		TRAMP RELEASE CYL		191.3
1	10 2856 3433	1	CYLINDER SUB-ASSEMBLY	A2	116
2	10 9429 0196	1	ROD ASSEMBLY	A2	53
3	10 3771 1920	1	GLAND	A2	21
4	10 6390 2195	1	STOP TUBE	A3	1.3
5	10 0725 8600	2	SEAL	A4	
6	10 0725 6413	1	SEAL	A4	
7	10 6280 5700	1	SEAL GUARD	A4	
9	10 3571 3195	1	O-RING	A4	
10	10 3571 3073	1	O-RING	A4	
11	10 8610 9906	1	BACK-UP RING	A4	

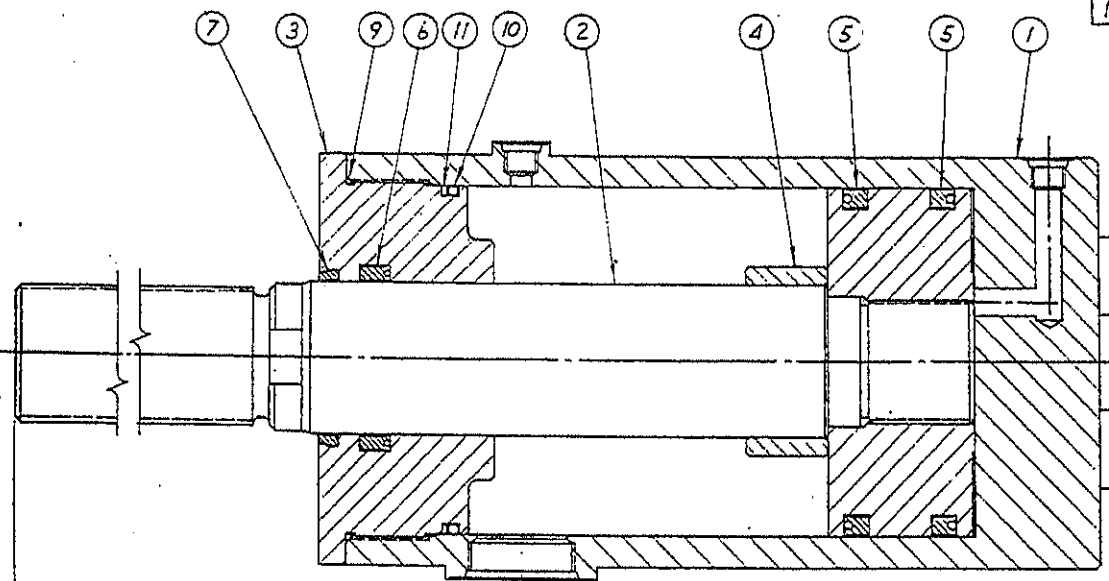

1190 NORMAL WORKING POSITION
 1177 FULLY RETRACTED
 1329 FULLY EXTENDED

203 BORE
 89 ROD
 152 STROKE

METRIC
 ALL DIMENSIONS IN MILLIMETERS

Rexnord Process Machinery Division

IMPLIED TOLERANCES	DATE 11/8/83	SUPERSEDED BY	ASSEMBLY GRC?
FURNISHED DIMENSIONS	ENGINEER C. DAVIS	SUPERSEDED BY	CRUSHER
MILLIMETERS	DATE 12 SEPT 83	PRODUCT	1560 OMNICON
APPROVED J.J.L.	DATE 20 APR 79	DESCRIPTION	

REV.	DESCRIPTION OF CHANGE	LOC.	BY DATE	ENGL. ORDER NUMBER
M	UPDATED TO ISO9000 STD		RDE 20 APR 79	100361
N	REMOVED ITEM 8; 12; 13		A-LAWRENCE 21 JUL 81	54176
O	ITEM 12 3570 9663 WAS 3570 9662		W.L.H. 25 MAR 82	52605
P	ADDED ITEMS 12 & 13.	CG	C.S. BRYANT 18 AUG 87	47989
Q	ISSUED		C.S. BRYANT 13 SEP 88	42514

SCALE 1:2	DWG. NO. 110 9429 0195	REV. D
DATE 11/8/83	DATE 11/8/83	DATE 11/8/83
SCALE 1:2	DATE 11/8/83	DATE 11/8/83

SURFACE PREPARATION, CLEANING AND PAINTING SYMBOLS ACCORDING TO COMPANY STANDARD 03-91-01.